

Swift Nest Brick

CODE **GSWB**

Description

As modern building practices have greatly improved the quality of new homes in the UK, some have actually suffered from the advances in building regulation. Bird species such as swifts have occupied the cracks and crevices in our buildings for thousands of years, but the improved standard and style of modern construction has put their survival in our towns and cities at risk.

These popular birds come to the UK for three months during the summer to raise their young and can be seen on warm evenings giving spectacular displays. They eat large quantities of insect pests and spiders. They prefer nesting in small groups but the population has been dwindling for many years as suitable nest sites have become scarcer.

The Manthorpe Swift Brick has been developed in conjunction with major house builders and conservation experts to provide a safe, spacious and habitable area to allow swifts to nest within the well built construction of modern houses.

Weight	0.71kg
Box Qty	2 (1.48kg per box)
Materials - Base Top	PVC Polypropylene
Colours	Terracotta, Slate Grey, Antique Red, Buff, White & Black
Manufacturing	Injection Moulded

Features

- Takes the place of a single brick the coloured face blends in to the surrounding masonry.
- Neat and simple to install, can be fitted quickly during the bricklaying.
- Integral nest concave provides ideal starting point for nest building.
- The birds have access via a 29 x 65 mm opening leading into a recessed entry tunnel.
- 413cm² of floor area gives the maximum habitable living space within the wall construction.
- A built in cavity tray detail within the roof of the brick protects against water ingress.

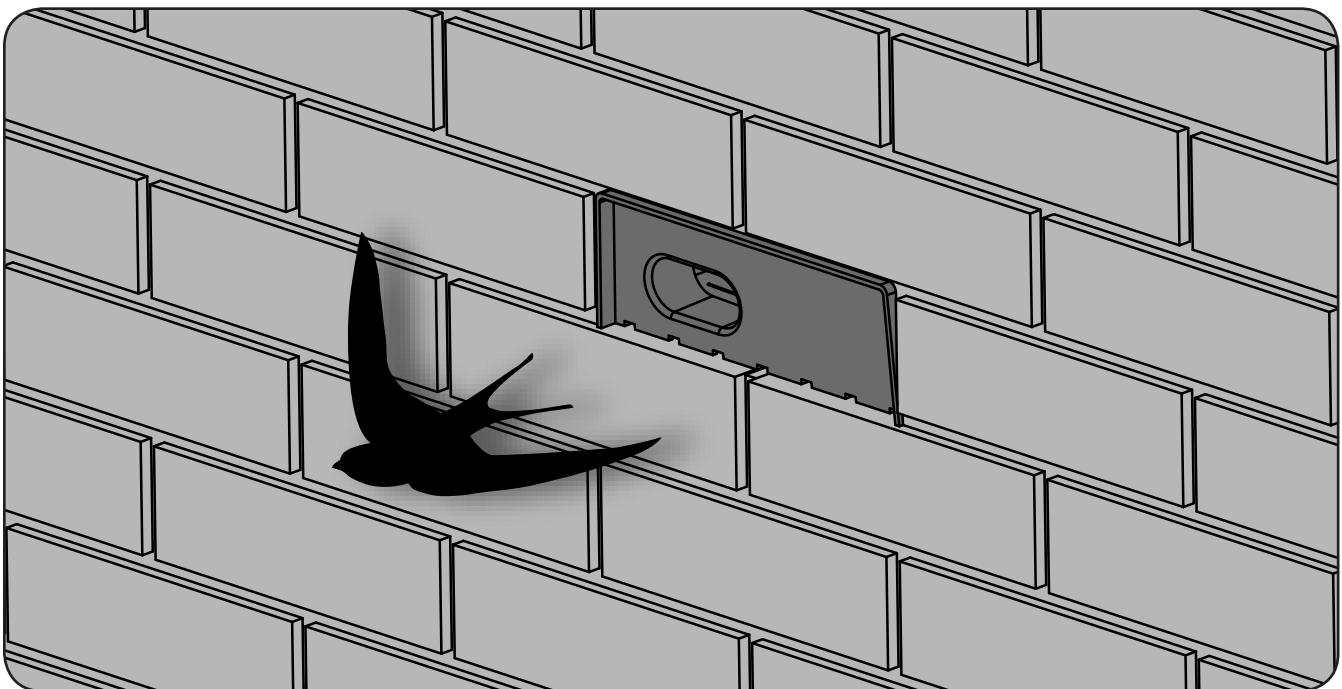

MANTHORPE BUILDING PRODUCTS LTD
 MANTHORPE HOUSE
 BRITAIN DRIVE
 CODNOR GATE BUSINESS PARK
 RIPLEY
 DERBYSHIRE DE5 3ND

TEL: 01773 514 200
 FAX: 01773 514 262
 EMAIL: bpsales@manthorpe.co.uk
 WEB www.manthorpe.co.uk

DRN B.H. Date 20.07.16

The company maintains a policy of continuous development of its product range and reserves the right to amend the specification without notice.

DRG No

MBP 8317

Issue

A
1 of 2

Swift Nest Brick

CODE **GSWB**

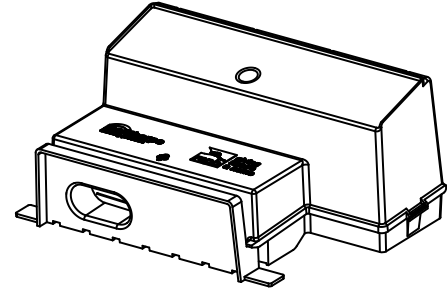
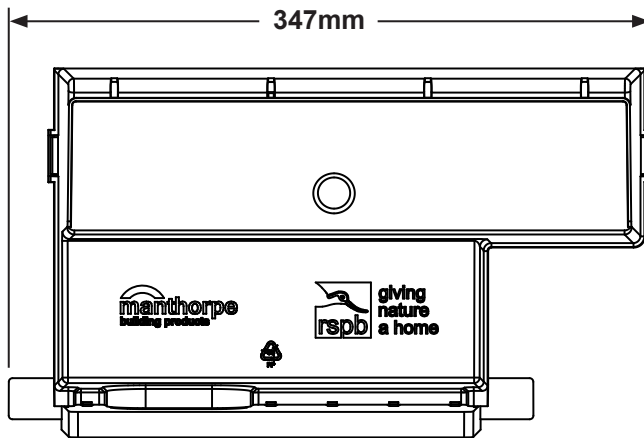

Entrance opening
29 x 65mm

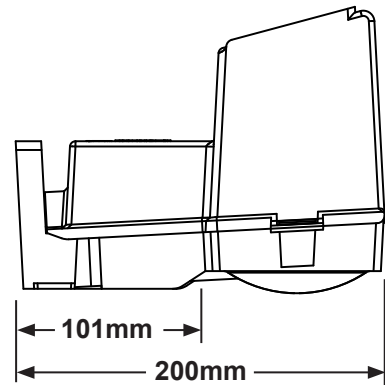
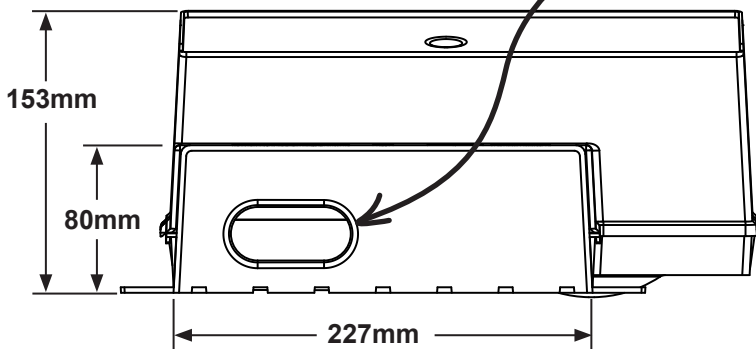

Placement Overview

The Swift Brick should be located high within the gable wall of the property, ideally at 5 metres high and above and over the level of the insulation zone. Where possible, install in locations that are unlikely to receive large amounts of direct sunlight during the hottest times of the day, ideal places include below the overhang of the verge and barge board.

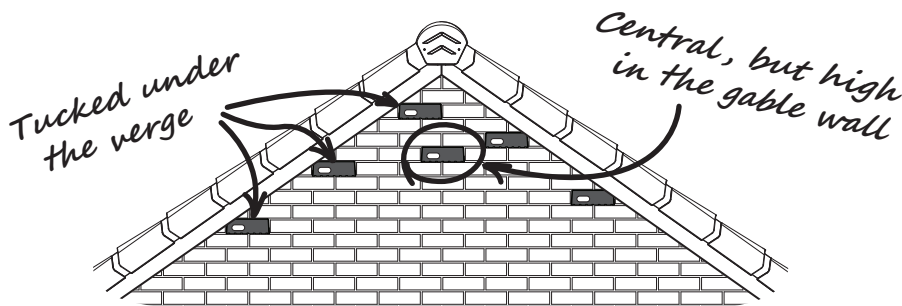

Developed in partnership with



MANTHORPE BUILDING PRODUCTS LTD
MANTHORPE HOUSE
BRITTAIN DRIVE
CODNOR GATE BUSINESS PARK
RIPLEY
DERBYSHIRE DE5 3ND

TEL: 01773 514 200
FAX: 01773 514 262
EMAIL:
bpsales@manthorpe.co.uk
WEB
www.manthorpe.co.uk

DRN B.H. Date 20.07.16

The company maintains a policy of continuous development of its product range and reserves the right to amend the specification without notice.

DRG No

MBP 8317

Issue

A
2 of 2